



### CURTAIN FIRE DAMPER:

Fire dampers are passive fire protection products used in heating, ventilation, and air conditioning (HVAC) ducts to prevent the spread of fire inside the ductwork through fire resistance rated walls and floors.

A fire damper can be defined as "a device installed in ducts and air transfer opening of an air distribution or smoke control system designed to close automatically upon detection of heat. It also serves to interrupt migratory airflow, resist the passage of flame, and maintain the integrity of the fire rated separation."

Its primary function is to prevent the passage of flame from one side of a fire-rated separation to the other.



**FUSIBLE LINK**

**OPERATION:** Fire dampers (Figure 1) are operated by a fusible device, typically a melting link. They are designed and tested under UL Standard 555: Standard for Safety for Fire Dampers, to maintain the integrity of the fire-rated separation. Fire dampers are equipped with a fusible link (rated for 165°F up to 286°F), which holds the blades open until it the link melts. Upon reaching the melting point, the blades then close and stop the flame from moving into an adjoining compartment.



**SLEEVES & ATTACHEMENT:-** Fire dampers are required to be installed in sleeves. Lighter gauge sleeves (18–20 ga.) require a breakaway connection from the sleeve to the ductwork. Heavier, smaller dampers (16 ga.) can be installed with a hard duct connection.

**SEALING:-**The spaces between the damper frame and the duct typically are not sealed due to thermal expansion. Breakaway connections as well as other seams can be sealed if the manufacturer's listing includes a UL-approved sealant.

There are two types of applications for fire dampers: static and dynamic.

Static fire dampers can only be applied in HVAC systems that are designed to shut down in the event of a fire. Dynamic fire dampers have been tested for closure under airflow and carry both an airflow velocity (fpm) and pressure differential rating. The minimum rating for all dynamic fire dampers is 2,000 fpm and 4.0 in. wg. The minimum ratings are based upon closure at a minimum airflow of 2,400 fpm and 4.5 in. wg.

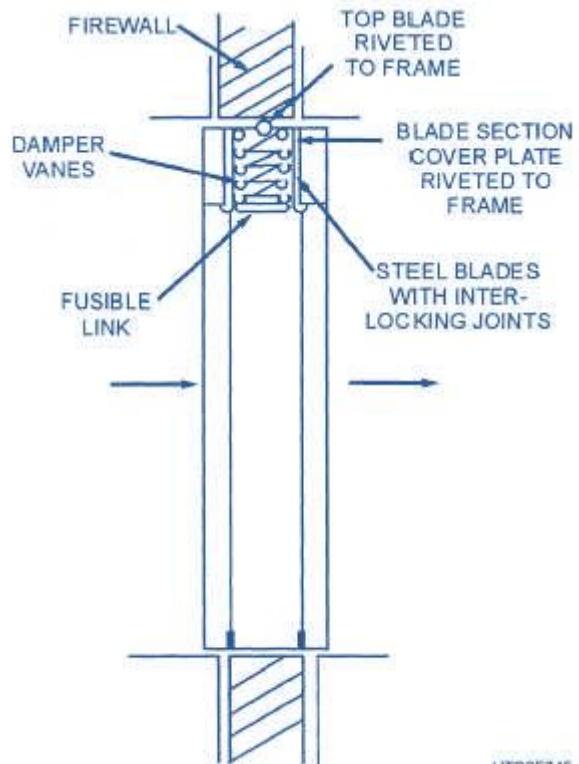

UTB2F745

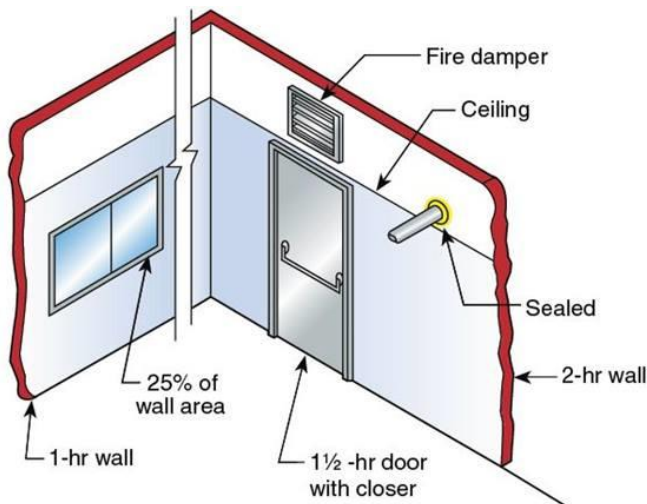

**LOCATION:-**Fire dampers are installed in or near the wall or floor, at the point of duct penetration, to retain the integrity and fire rating of a wall or floor whether it is a ducted or open-plenum return application. Should the ductwork fall away, the damper needs to stay in the wall or floor to maintain the integrity of the wall or floor. One should actually think of the fire damper as part of the wall system itself.



Fire Dampers are evaluated for use as either:

**a) Fire Dampers for Static Systems -**

For systems that are automatically shut down in the event of a fire.  
HVAC

**b) Fire Dampers for Dynamic Systems**

For HVAC systems that are operational in the event of a fire.

**c) Combination Fire and Smoke Dampers**

For locations in systems where a Fire Damper and a Smoke Damper are required at a single location.

The UL 555 standard for fire dampers includes significant test criteria.

- Operational reliability To ensure operation through 250 cycles for dampers for use without actuators, or 20,000 cycles for dampers with actuators and cycle testing following salt spray exposure.

- Fire test For either 1 1/2 or 3 hours to determine the hourly classification of the damper assembly.
- Hose stream test To verify the damper assembly and associated installation components remain intact during explosive fire conditions.

- Dynamic closure To verify the damper assembly will close against heated air flow velocity of at least 2000 fpm and 4 inches of water. (Not required for dampers classified for static "fans off" systems).

DAMPER TYPE	UL 555 TEST CRITERIA				FOR USE IN	
	OPERATIONAL	FIRE	HOSE STREAM	DYNAMIC CLOSURE	ALL SYSTEMS	STATIC SYSTEMS ONLY
DYNAMIC	X	X	X	X	X	
STATIC	X	X	X			X



**MODEL: SAS-FD-A**

### STANDARD CONSTRUCTION

**FRAME:**

1.2 mm high quality galvanized steel sheet.

**BLADES:**

0.85 mm interlocking type roll formed blades from galvanized sheet

**FINISH:**

Mill galvanized.

**BLADE RAMP:**

1.6mm thick galvanized steel sheet with a spring holder.

**SPRING:**

Coil tension stainless steel spring .

**FUSIBLE LINK:**

UL Listed fusible link 165°F as standard.

**MINIMUM & MAXIMUM SINGLE SECTION SIZE:**

100 x 100mm minimum & 1000x1000 mm maximum.

**MOUNTING:**

Horizontal or Vertical

**SLEEVES:**

300 mm sleeve with 20ga steel available on request

**MICROSWITCH:**

Optional

**FIRE RATING:**

1.5 HRS & 3 HRS

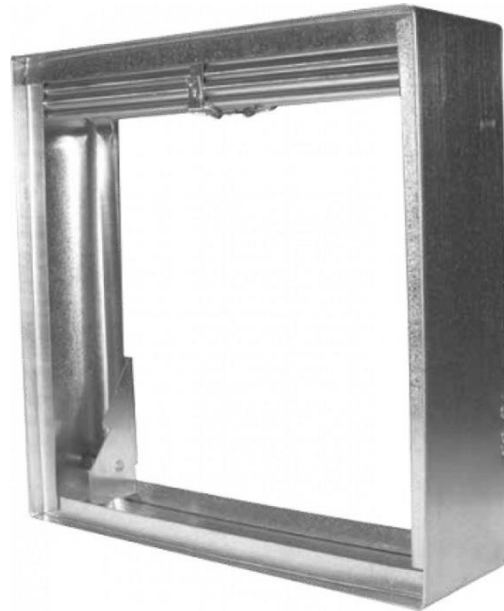

**BLADE INSIDE AIR STREAM**

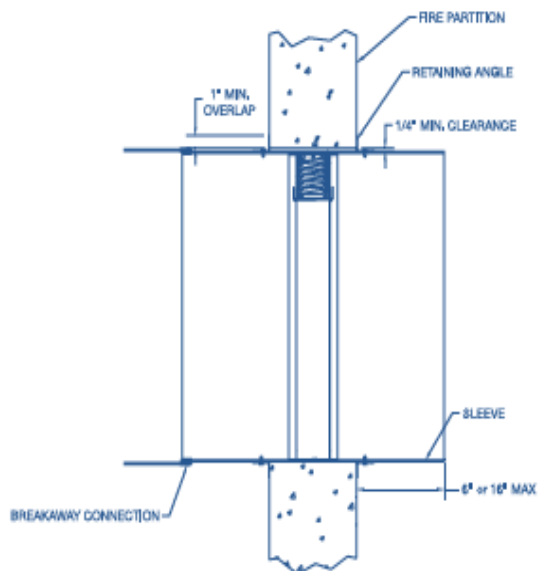



**MODEL: SAS-FD-B**  
**STANDARD CONSTRUCTION**

**FRAME:**  
 1.2 mm high quality galvanized steel sheet.

**BLADES:**  
 0.85 mm interlocking type roll formed blades from galvanized sheet

**FINISH:**  
 Mill galvanized.

**BLADE RAMP:**  
 1.6mm thick galvanized steel sheet with a spring holder.

**SPRING:**  
 Coil tension stainless steel spring .

**FUSIBLE LINK:**  
 UL Listed fusible link 165°F as standard.

**MINIMUM & MAXIMUM SINGLE SECTION SIZE:**  
 100 x 100mm minimum & 1000x1000 mm maximum.

**MOUNTING:**  
 Horizontal or Vertical

**SLEEVES:**  
 300 mm sleeve with 20ga steel available on request

**MICROSWITCH:**  
 Optional

**FIRE RATING:**  
 1.5 HRS & 3 HRS



**BLADE OUTSIDE AIR STREAM**



**FIRE DAMPER WITH SLEEVE**



**CURTAIN FIRE DAMPER MODELS**

SAS-FD-A	Blades in air stream
SAS-FD-B	Blades outside air stream
SAS-FD-AS	Blades in air stream with sleeve
SAS-FD-BS	Blades outside air stream with sleeve
SAS-FD-R	With round spigot
SAS-FD-O	With oval Spigot

Vertical Mount

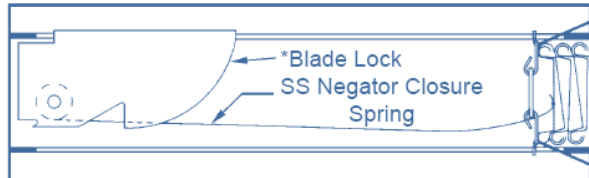
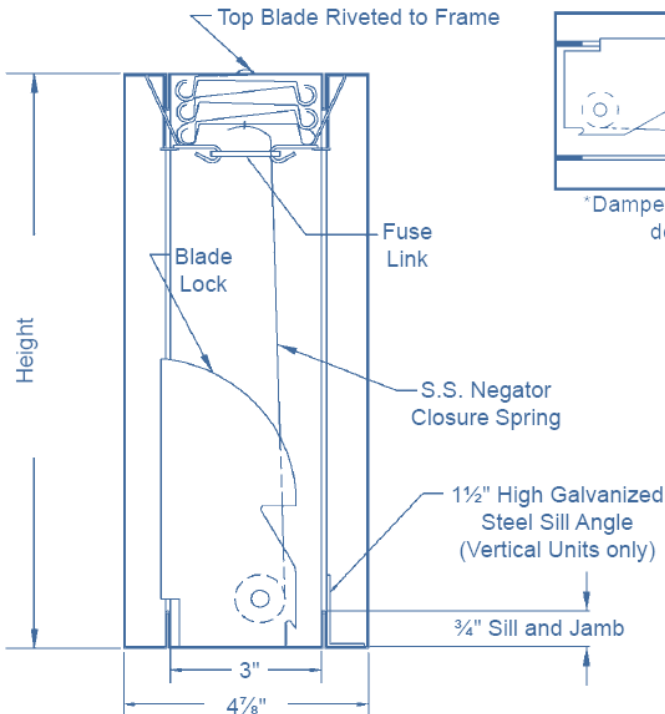

\*Damper to be installed with blade lock points facing downward and with access from above

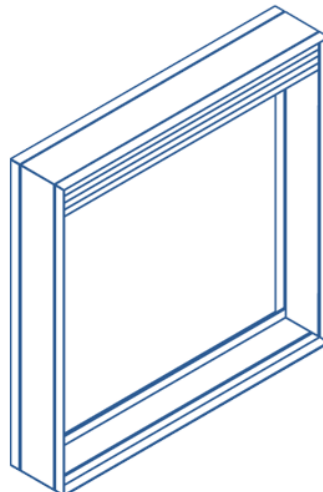

Horizontal Mount