

# Pegler Valve

Bronze swing type check valve BS5154 PN25 Series B, metal disk

1060A Check valve



## General Information

Size	Pattern No.	Pack 1 Qty	Pack 2 Qty	Code	Barcode	Price (£) each ex VAT
1/2"	1060A	1	10	<a href="#">122007</a>	5022050546135	£32.63
3/4"	1060A	1	10	<a href="#">122008</a>	5022050546142	£39.96
1"	1060A	1	5	<a href="#">122009</a>	5022050546159	£52.73
1.1/4"	1060A	1	2	<a href="#">122010</a>	5022050546166	£76.37
1.1/2"	1060A	1	2	<a href="#">122011</a>	5022050546173	£108.38
2"	1060A	1	0	<a href="#">122012</a>	5022050545640	£164.78
2.1/2"	1060A	1	0	<a href="#">122013</a>	5022050545657	£378.36
3"	1060A	1	0	<a href="#">122014</a>	5022050545664	£535.01
4"	1060A	1	0	<a href="#">122015</a>	5022050545671	£1623.14
1/2"	1060A AT	1	10	<a href="#">122027</a>	5022050566478	£33.57
3/4"	1060A AT	1	10	<a href="#">122028</a>	5022050566485	£44.40
1"	1060A AT	1	5	<a href="#">122029</a>	5022050566508	£61.48
1.1/4"	1060A AT	1	2	<a href="#">122030</a>	5022050566751	£98.15
1.1/2"	1060A AT	1	2	<a href="#">122031</a>	5022050566768	£120.88
2"	1060A AT	1	0	<a href="#">122032</a>	5022050566775	£195.57
2.1/2"	1060A AT	1	0	<a href="#">122033</a>	5022050566782	£378.36
3"	1060A AT	1	0	<a href="#">122034</a>	5022050566799	£535.01
1/2"	1060A PT	1	10	<a href="#">122047</a>	5022050546180	£33.57
3/4"	1060A PT	1	10	<a href="#">122048</a>	5022050546197	£44.40
1"	1060A PT	1	5	<a href="#">122049</a>	5022050546203	£61.48
1.1/4"	1060A PT	2	0	<a href="#">122050</a>	5013866013935	£98.15
1.1/2"	1060A PT	1	2	<a href="#">122051</a>	5022050546210	£120.88
2"	1060A PT	1	8	<a href="#">122052</a>	5022050545688	£195.57
2.1/2"	1060A PT	1	0	<a href="#">122053</a>	5022050576187	£378.36
3"	1060A PT	1	0	<a href="#">122054</a>	5022050576194	£535.01
4"	1060A PT	1	0	<a href="#">122055</a>	5022050576279	£1623.14

1060A Check valve

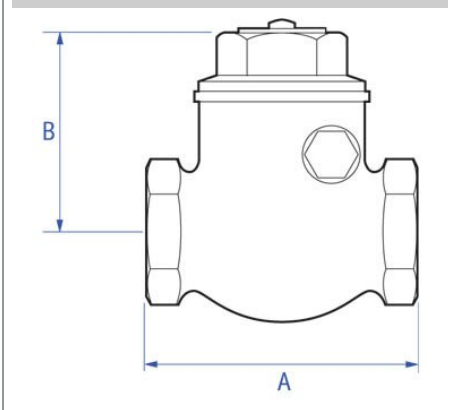

## Dimensions

Code	Description	A	B
122007	1/2" 1060A GM SWING CHECK VALVE	62	45 0.38
122008	3/4" 1060A GM SWING CHECK VALVE	76	55 0.58
122009	1" 1060A GM SWING CHECK VALVE	83	60 0.86
122010	1.1/4" 1060A GM SWING CHECK VALVE	94	65 1.26
122011	1.1/2" 1060A GM SWING CHECK VALVE	105	75 1.66
122012	2" 1060A GM SWING CHECK VALVE	125	90 2.66
122013	2.1/2" 1060A GM SWING CHECK VALVE	161	112 3.44
122014	3" 1060A GM SWING CHECK VALVE	172	132 4.52
122015	4" 1060A GM SWING CHECK VALVE	222	130 8.38
122027	1/2" 1060A AT GM SWING CHECK VALVE	62	45 0.38
122028	3/4" 1060A AT GM SWING CHECK VALVE	76	55 0.58
122029	1" 1060A AT GM SWING CHECK VALVE	83	60 0.86
122030	1.1/4" 1060A AT GM SWING CHECK VALVE	94	65 1.26
122031	1.1/2" 1060A AT GM SWING CHECK VALVE	105	75 1.66
122032	2" 1060A AT GM SWING CHECK VALVE	125	90 2.66
122033	2.1/2" 1060A AT GM SWING CHECK VALVE	161	112 3.44
122034	3" 1060A AT GM SWING CHECK VALVE	172	132 4.52
122047	1/2" 1060A PT GM SWING CHECK VALVE	62	45 0.38
122048	3/4" 1060A PT GM SWING CHECK VALVE	76	55 0.58

Code	Description	A	B
122049	1" 1060A PT GM SWING CHECK VALVE	83	60 0.86
122050	1.1/4" 1060A PT GM SWING CHECK VALVE	94	65 1.26
122051	1.1/2" 1060A PT GM SWING CHECK VALVE	105	75 1.66
122052	2" 1060A PT GM SWING CHECK VALVE	125	90 2.66
122053	2.1/2" 1060A PT GM SWING CHECK VALVE	148	110 3.52
122054	3 1060A PT GM SWING CHECK VALVE	175	125 4.48
122055	4 1060A PT GM SWING CHECK VALVE	222	130 8.38

Pegler Yorkshire reserve the right to change specifications

### Flow Rate

Size	Pattern No.	Code	Flow l/s	Kv m3/h	Cv - US GPM
1/2"	1060A	122007	0.04	1.80	
			0.10	3.70	-
			0.20	5.10	
			0.40	5.70	
3/4"	1060A	122008	0.04	2.70	
			0.10	5.50	-
			0.40	13.60	
			1.00	15.30	
1"	1060A	122009	0.01	7.70	
			0.20	13.90	-
			0.30	18.40	
			1.00	25.30	
1.1/4"	1060A	122010	0.20	15.00	
			0.30	26.60	-
			0.40	25.30	
			1.00	32.60	
1.1/2"	1060A	122011	0.40	30.30	
			0.60	40.20	-
			0.80	48.50	
			3.00	54.40	
2"	1060A	122012	0.60	42.00	
			0.80	54.00	-
			1.50	86.20	
			4.00	98.00	
2.1/2"	1060A	122013	1.50	97.60	
			3.00	135.30	-
			4.00	156.00	
			2.00	144.60	
3"	1060A	122014	3.00	168.40	-
			5.00	229.00	
4"	1060A	122015			
			0.04	1.80	2.10
			0.10	3.70	4.30
			0.20	5.10	5.90
1/2"	1060A AT	122027	0.40	5.70	6.50
			0.04	2.70	3.10
			0.10	5.50	6.30
			0.40	13.60	15.60
3/4"	1060A AT	122028	1.00	15.30	17.60
			0.01	7.70	8.80
			0.20	13.90	16.00
			0.30	18.40	21.10
1"	1060A AT	122029	1.00		
			0.20	15.00	17.2
			0.30	26.60	23.7
			0.40	25.30	29.1
1.1/4"	1060A AT	122030	1.00	32.60	37.5
			0.40	30.30	34.80
			0.60	40.20	46.20
			0.80	48.50	55.70
1.1/2"	1060A AT	122031	3.00	54.40	62.50
			0.60	42.00	48.30

**Size Pattern No. Code Flow l/s Kv m3/h Cv - US GPM**

2"	1060A AT	122032	0.80	54.00	62.00
			1.50	86.20	99.00
			4.00	98.00	112.60
			1.50	97.60	
2.1/2"	1060A AT	122033	3.00	135.30	-
			4.00	156.00	
			2.00	144.60	
3"	1060A AT	122034	3.00	168.40	-
			5.00	229.00	
			0.04	1.80	
1/2"	1060A PT	122047	0.10	3.70	-
			0.20	5.10	
			0.40	5.70	
			0.04	2.70	
3/4"	1060A PT	122048	0.10	5.50	-
			0.40	13.60	
			1.00	15.30	
			0.01	7.70	
1"	1060A PT	122049	0.20	13.90	-
			0.30	18.40	
			1.00	25.30	
1.1/4"	1060A PT	122050	0.20	15.00	
			0.30	20.60	-
			0.40	25.30	
			1.00	32.60	
1.1/2"	1060A PT	122051	0.40	30.30	
			0.60	40.20	-
			0.80	48.50	
			3.00	54.40	
2"	1060A PT	122052	0.60	42.00	
			0.80	54.00	-
			1.50	86.20	
			4.00	98.00	
2.1/2"	1060A PT	122053			
3	1060A PT	122054			
4	1060A PT	122055			

**Pegler Yorkshire reserve the right to change specifications**

## Guarantee

### Valves and Fittings

#### **Pegler Yorkshire Customcare 5 Year Guarantee - Terms and Conditions**

Products are subject to a 5 year guarantee that is between Pegler Yorkshire and the final purchaser of the product.

The guarantee is subject to proof of purchase being supplied.

This guarantee does not affect any statutory rights the consumer may have in law.

The guarantee covers manufacturing or material defects and does not cover parts subject to normal wear and tear.

This product range has been designed for the use of homeowners, domestic and commercial applications and therefore the guarantee is subject to the product being properly selected for their intended service conditions.

The guarantee is not applicable where the product is fitted contrary to the conditions in the fitting instructions.

This is reinforced where valves are covered by the European Pressure Equipment Directive (PED97/23/EC) where Installation, Operating and Maintenance Instructions are supplied with each product and/or carton.

Provided it is installed correctly and receives adequate preventative maintenance it should give years of trouble-free service.

Abusive behaviour and accidental damage to the product are not covered by this guarantee.

The extent of this liability is limited to the cost of the replacement of the defective item and not to fitting or consequential damages.

## Pressure and Temperature

Description	Minimum Operating Pressure (bar)	Maximum Cold Working Pressure (bar)	Maximum Hot Working Pressure (bar)
1060A Swing Check Valve	0.5 -1.0 bar	25.0 bar at temperatures up to 100oC	10.5 bar at temperatures up to 186oC

## Care and Maintenance

### Care

No regular aesthetic care is required for this product

### Maintenance

A regular maintenance program is the most efficient method of ensuring longer term operational efficiency of the selected valve. Such a program would need to include a risk assessment and a planned procedure of how the maintenance will be carried out. The possibility of operational limits being exceeded and the potential hazards ensuring must be considered as part of this assessment. This should be implemented to include visual checks on the valve's condition and any development of unforeseen conditions, which could lead to failure. The correct fitting tools and equipment should be used for valve maintenance work. Separate means of draining the pipe work must be provided when carrying out any maintenance to valves. Where there may be any system debris this could be collected and /or filtered by installation of the appropriate protective device.

For further help please contact your local engineer.

If your product is under warranty please contact the Service Support Team on: 0800 1560050

## Regulations

### Regulations

#### THE PRESSURE EQUIPMENT DIRECTIVE 97/23/EC and CE MARKING

The Pressure Equipment Regulations 1999 (SI 1999/2001) have now been introduced into United Kingdom law.

Valves with a maximum allowable pressure greater than 0.5 bar are covered by these new Regulations. Valves are categorised according to their maximum working pressure, size and rising level of hazard. The level of hazard varies according to the fluid being carried. Fluids are classified as Group 1, dangerous fluids or Group 2, all other fluids including steam. The Categories designated are SEP (sound engineering practice). Valves up to and including 25mm (1") are designated SEP regardless of the fluid group. Those identified as having increased hazard are Categorised as, I, II, III or IV. All valves designated as SEP do not bear the CE mark nor require a Declaration of Conformity. Categories I, II, III or IV carry the CE mark and require a Declaration of Conformity. Valves classified from the piping chart would not be included in Category IV.

#### Size Pattern No. Code PED Categorisation

1/2"	1060A	122007	SEP
3/4"	1060A	122008	SEP
1"	1060A	122009	SEP
1.1/4"	1060A	122010	SEP
1.1/2"	1060A	122011	SEP
2"	1060A	122012	SEP
2.1/2"	1060A	122013	SEP
3"	1060A	122014	SEP
4"	1060A	122015	SEP
1/2"	1060A AT	122027	-
3/4"	1060A AT	122028	-
1"	1060A AT	122029	-
1.1/4"	1060A AT	122030	-
1.1/2"	1060A AT	122031	-
2"	1060A AT	122032	-
2.1/2"	1060A AT	122033	-
3"	1060A AT	122034	-
1/2"	1060A PT	122047	-
3/4"	1060A PT	122048	-
1"	1060A PT	122049	-
1.1/4"	1060A PT	122050	-
1.1/2"	1060A PT	122051	-
2"	1060A PT	122052	-
2.1/2"	1060A PT	122053	-
3"	1060A PT	122054	-

**Size Pattern No. Code PED Categorisation**

4 1060A PT 122055 -

Pegler Yorkshire reserve the right to change specifications

**Materials**

Component	Material
Body	Gunmetal
Cap	Forged Brass (1/4" to 2") Gunmetal (2.1/2" to 4")
Valve	Gunmetal
Swinger	Brass Bar (1/4" to 1") Gunmetal (1.1/4" to 4")
Swinger Pin	Brass Bar
Swinger Pin Cap (sizes 2 1/2" to 4" only)	Brass Bar
Nut	Brass Bar
Rating Disc	Tinned Iron Sheet

**Flange Data**

Flange Size Code	Flange Diameter (mm)	Pitch Circle Diameter (mm)	No of Bolts	Bolt Diameter (mm)	Hole Diameter (mm)	Raised Face Diameter (mm)	Raised Face Height (mm)	Thickness of Flange (mm)
Pegler Yorkshire reserve the right to change specifications								

**Technical Suitability**

Steam	Water	Oil	Air	Gas	Inert Gas	Combustible†	Gas Corrosive††	Gas Oxygen
yes	yes	yes	yes	no	no	no	no	no

Pegler Yorkshire reserve the right to change specifications

**Gas application guide**

Class 1. INERT Air, argon, carbon dioxide, helium, nitrogen

Class 2. COMBUSTIBLE Hydrogen, methane, natural gas, town gas

Class 3. CORROSIVE Chlorine, sulphur dioxide Class 4. OXYGEN

Class 1. INERT Air, argon, carbon dioxide, helium, nitrogen

† Valves are suitable for British Gas Applications Family Gases 1, 2 and 3.

†† Suitable in applications where moisture is completely absent.

# installation instructions

## the pressure equipment directive

### 97/23/EC & CE marking

The Pressure Equipment Regulations 1999 (SI 1999/2001) have now been introduced into United Kingdom law. Valves with a maximum allowable pressure greater than 0.5 bar are covered by these new Regulations. Valves are categorised according to their maximum working pressure, size and rising level of hazard. The level of hazard varies according to the fluid being carried. Fluids are classified as Group 1, dangerous fluids or Group 2, all other fluids including steam. The categories designated as SEP (sound engineering practice). Valves up to and including 25mm (1") are designated SEP regardless of the fluid group. Those identified as having increased hazard are categorised as, I, II, III or IV. All valves designated as SEP do not bear the CE mark nor require a Declaration of Conformity. Categories I, II, III or IV carry the CE mark and require a Declaration of Conformity. Valves classified from the piping chart would not be included in Category IV.

### CE marking & the ATEX Directive 94/9/EC

Concerning equipment and protection systems intended for use in potentially explosive atmospheres. This has been implemented in United Kingdom law by the Equipment and Protective Systems Intended for Use in Potentially Explosive Atmosphere Regulations 1996 (SI 1996/192) and amended by The Equipment and Protective Systems (amendment) Regulations 2001 (SI2001/3766). The regulations apply to all valves where each valve: a) has its own potential source of ignition. b) operates in a potentially explosive atmosphere created by:

- i) the presence of air/dust mixtures external to the valve.
- ii) the presence of gases, vapours, mists released from the valve through leakage.

The regulations will not apply to a valve without a potential source of ignition, which operates in a dust free environment and the fluid being transported is cold, inert gas or non-flammable liquid. The requisite level

of protection for valves not exempt from the regulations is defined as Group II category 2 and shall bear the following markings: ExII 2 GD X

## valve selection

### selection, storage & protection

Valves must be properly selected for their intended service conditions. Provided it is installed correctly and receives adequate preventative maintenance it should give years of trouble-free service. They must be compatible with the system design, pressure and temperature requirements and must be suitable for the fluids that they are intended to carry. Interactions between metals in the pipe system and the valve must be considered as part of the valve selection.

Valves should be stored off the ground in a clean, dry, indoor area. Where desiccant bags are included with the valve these should be changed after a period of 6 months.

Pegler valves are supplied in cardboard cartons or are bagged as appropriate and so adequate protection from damage is provided. When Pegler valves are fitted with pressure equipment or assemblies, suitable protective devices may be required.

### pressure/temperature rating

Valves must be installed in a piping system whose normal pressure and temperature does not exceed the stated rating of the valve. The maximum allowable pressure in valves as specified in the standards is for non-shock conditions. Water hammer and impact should also be avoided.

If system testing will subject the valve to pressures in excess of the working pressure rating, this should be within the "shell test pressure for the body" to a maximum of 1.5 times the PN rating and conducted with the valve fully opened.

It may be hazardous to use these valves outside of their specified pressure and temperature limitations and also when not used for the correct application.

### location/end-of-line service

To ensure ease of operation, adjustment, maintenance and repair, valve siting should be decided during the system design phase. To prevent imposing strain on the valve seat, pipe work and valves they must be adequately supported.

The 1072, 1070/125, 1065 and 1068 Gate valves are suitable for end of line service but we strongly recommend the fitting of a blanking plug to the downstream end of the valve. Pegler Ball, Globe, Check, Flanged and Lever Gate valves are not suitable for end-of-line service.

## installation

### health & safety

Before starting work on any installation a risk assessment must be made to consider the possibility of operational limits being exceeded and reduction or elimination of any potential hazards.

1. Protective clothing and safety equipment must be utilised as appropriate to the hazard presented by the nature of the process to which the valve is being installed or maintained.
2. Before installing or removing a valve the pipeline circulating pumps (when fitted) must be turned off. The pipeline must be depressurised, drained and vented. Valves must be fully opened to ensure release of any pipeline or valve pressure.
3. Fitters must be trained in manual and mechanical handling to enable them to safely lift and install Pegler valves.
4. The valve selected must be suitable for the required service conditions. The pressure and temperature limitations are indicated on the valve nameplate, body or data plate. These must not be exceeded.
5. Valve seats, seals and internal components can be damaged by system debris. Protective devices may need to be fitted and system flushing may be required.
6. Any flushing fluid used to clean the pipeline must not cause any damage to the valve and its components.
7. Pegler valves must not be misused by lifting them by their hand wheels, levers or stems.

8. Pegler valves are not suitable for fatigue loading, creep conditions, fire testing, fire hazard environment, corrosive or erosive service, or for carrying fluids containing abrasive solids. There is no allowance for corrosion in the design of these valves. Designs for this valve do not allow for decomposition of unstable fluids and must not be used where this could occur.

9. Pegler valves are not designed to withstand the effects of fire, wind, earthquakes and traffic.

10. All Health and Safety Rules must be followed when installing and maintaining valves.

### installation

Unpack the valve and check that the flow paths and valve threads are clean and free from debris.

Check the body markings and nameplate to ensure that the correct valve has been selected for installation.

Gate valves and Globe valves may be fixed in "Vertical pipe work with stem horizontal" or "Horizontal pipe work with stem vertical and upright". Globe valves are marked with a directional flow arrow on the body. The valve will function correctly providing it is fitted so that the fluid transported follows the indicated flow direction.

Make sure that a gate valve is fully closed during installation.

Fitting a gate valve in the open position may cause twisting and the gate and seating may not mate properly. The valve should be operated from fully open to fully closed to test that it has been correctly installed.

The valve should not be installed in horizontal pipe work with stem horizontal because full closure may be impeded by an accumulation of system debris. Pegler Valves are manufactured to exacting standards and, therefore, should not be subjected to misuse. The following should be avoided: **\*careless handling** of the valve (Valves should not be lifted using the hand wheel, lever or the stem). **\*dirt and debris** entering the valve through the end ports. **\*Excessive force** during assembly and hand wheel operation.

Ball valves may be fixed in any orientation, always leaving enough space for the 90° operation of the lever handle. Horizontal and vertical pattern check valves may be fitted in horizontal pipe work with the cap

upper most and vertically with the flow in an upwards direction. The valve is marked with a directional flow arrow on the body. The valve will function correctly providing it is fitted so that the fluid transported follows the indicated flow direction. Check valves having 6 diameters of straight length of pipe upstream and 3 diameters downstream are suitable for velocities of 3 metres per second. If the valve is situated such that non uniform or pulsating flow enters the valve, e.g. the valve is close to reciprocating pumps, then the velocity should not exceed 2 metres per second. Use suitable hangers close to both ends of the valve in order to remove stresses transmitted by the pipe. Confirm that the pipe threading length is correct to avoid excessive penetration of the pipe into the valve that would otherwise cause damage. Care should be taken to apply jointing compound to the pipe only and not in the valve threads. Surplus compound will then be forced outwards and will not enter the valve. Over use of compound can lead to valve failure on the body ends. Threads should be engaged correctly when tightening the valve onto the pipe. The wrench should always be fitted on the body end adjacent to the joint being made. Severe damage can occur to stems, valves and seats by the use of hand wheels or levers larger than those originally supplied by the manufacturer, and by wheel keys. Any electrical component e.g. actuators, limit switches must be explosion proof and comply with the ATEX Directive and Standards as listed in BS EN 1127-1 clause 6.4.5.

## operation

### gate valves

To open - an anti-clockwise rotation of the hand wheel will open the valve. When it will go no further return the hand wheel clockwise 1/2 turn. To close the valve a clockwise rotation of the hand wheel will close the valve. Closure will be confirmed when the handle can be turned no further.

**caution:** Service applications with extremes of temperature may cause the wedge to become tight in the valve. The valve may become stiff to operate in these circumstances. Suitable hand protection should be worn when operating valves used in extreme temperature applications. The valve should only be used in the fully open or fully closed position. Gate valves are not suitable for regulating and throttling service.

### globe valves

To open - an anti-clockwise rotation of the hand wheel will open the valve. When it will go no further return the hand wheel clockwise 1/2 turn. To close the valve a clockwise rotation of the hand wheel will close the valve. Closure will be confirmed when the handle can be turned no further.

**caution:** Suitable hand protection should be worn when operating valves used in extreme temperature applications. Globe valves are suitable for regulating and throttling service.

### check valves

The Horizontal/vertical pattern check valves operate according to the flow within the pipeline and there is no external method of operation.

### ball valves

**PB LEVER HANDLE** To open - turn the lever 90° so that it is in line with the pipe run in which it is installed. To close - turn the lever 90° so that it is across the line of the pipe in which it is installed. Full opening and closing is completed when a full 90° is achieved and the lever is firmly set against the stop on the valve body.

**PB T** Models have lockable handles for use in both open and closed positions. In the fully open position the T handle is in line with the pipe work. To lock the valve in the open position a hexagon key of the appropriate size can be used to remove the securing screw. The T handle can then be lifted from the valve. This should then be rotated through 180° and refitted on to the valve spindle ensuring the handle slot engages on to the body lug. Insert the securing screw and re-tighten with the hexagon key.

**PB EL** models are fitted with an extended spindle mechanism that lifts the lever away from the body and is particularly useful when pipe insulation is being used. This version is only available with a standard lever handle. Caution: Service applications with extremes of temperature may cause the ball to become tight in the valve. The valve may become stiff to operate in these circumstances. Suitable hand protection should be worn when operating valves used in extreme temperature applications. The valve should only be used in the fully open or fully closed position. Ball valves are not suitable for regulating or throttling applications.

## maintenance

A regular maintenance program is the most efficient method of ensuring longer term operational efficiency of the selected valve. Such a program would need to include a risk assessment and a planned procedure of how the maintenance will be carried out. The possibility of operational limits being exceeded and the potential hazards ensuing must be considered as part of this assessment. This should be implemented to include visual checks on the valve's condition and any development of unforeseen conditions, which could lead to failure. The correct fitting tools and equipment should be used for valve maintenance work. Separate means of draining the pipe work must be provided when carrying out any maintenance to valves. Where there may be any system debris this should be collected and/or filtered by installation of the appropriate protective device.

### gland adjustment

The gland may need adjustment during installation and then periodically thereafter to maintain a stem gland seal.

#### note:

it is recommended that within the 1st year the gland be inspected at 3 monthly intervals to check for gland leakage.

### gland replacement

Under normal working conditions Pegler gate and globe valves do not normally require any maintenance, however, in the event of maintenance being necessary, the following procedure should be followed: Before starting work, de-pressurise the system, turn off any circulating pumps. Slacken the hand wheel nut and remove the nut, nameplate and hand wheel. Remove the gland nut and gland ring. Using a suitable tool, lift out the existing packing and make sure the stem and stuffing box are clean & free from debris. Care must be taken not to damage the valve stem.

Fit a replacement Pegler packing gland into the stuffing box and push down firmly.

Re-assemble the gland ring and gland nut.

Re-attach the handwheel, nameplate and nut.

Tighten the gland nut and confirm stem resistance while operating the valve. Once line pressure is re-established a check for leak tightness should be made, further adjust the gland nut as required necessary to achieve a satisfactory seal.

#### note:

**maintenance Permanent removal of the gland nut and /or the Data. Plate will invalidate the CE compliance of this valve. Pegler Ball valves and Check valves are generally NOT suitable for maintenance.**

According to valve type, gland packing and valve discs may be replaced. Valves within the scope of the ATEX Directive with a protective level defined as Group II category 2 will operate in Zone 1 (gases/vapours) or Zone 21 (dust) designated in BS1127-1 Explosion prevention and protection. Tools are either "single spark" e.g. screwdriver, spanner, impact screwdriver or "shower of sparks" e.g. sawing or grinding. Only steel "single spark" tools are permitted in Zones 1 & 21. Tools causing showers of sparks are only permissible if: a) no hazardous explosive atmosphere is present. b) dust deposits have been removed and no dust cloud is present. The use of tools on equipment in Zones 1 and 21 should be subject to a "permit to work" system.

### 1029 renewable valve disc replacement

Before starting work de-pressurise the system, turn off any circulating pumps, and ensure the valve is empty of fluid. Using a suitable wrench remove the complete bonnet assembly from the valve. Care should be taken to ensure the pipework is held securely during this process so that there is no distortion to the valve threads. Any damage to the threads could lead to valve failure. Slacken and remove disc nut and disc.

Assess damage to valve seat replacing the whole valve if necessary.

The valve disc can be replaced with an equivalent size disc and type as appropriate. Re-attach a replacement disc and disc nut. Re-assemble the

bonnet in to the valve body, checking for damage. Ensure the valve bonnet is joined securely to body and will not leak.

#### note:

the 1029 Globe valves have non-metallic PTFE valve discs.

### installation, operating & maintenance instructions are available from sales office

Pegler recommended spares must be used. Refer to Pegler Technical Department for further information.

## product life span

When a valve is properly selected for its service conditions it should give years of trouble-free service provided it is installed correctly and receives adequate preventative maintenance. By not considering the compatibility of the system design and the pressure and temperature requirements the life expectancy of the valves can be adversely affected and valve failure may occur. The nature of the fluid being carried through the valve could also affect the valve performance as this could lead to premature valve failure. There may also be interactions between metals in the pipe system and the valve which need to be considered. Appropriate flushing and cleaning of the pipe work Installation should take place when commissioning the system as this would help extend the valve life. Reference Material: Pegler Valves Package Brochure, Pegler Spares Catalogue, and Spares Price list. A Technical File is held at Doncaster as part of the requirements for compliance to the European Pressure Equipment Directive (PED 97/23 EC).

**maintaining a policy of continual product development pegler ltd reserves the right to change specification, design and materials of products listed in this leaflet without prior notice.**



## valve suitability

	Product	PN	Non - shock pressure @ temp. range	Non - shock pressure @ max. range
ball valves	PB700	40*	40 bar - 10°C to 110°C	10 bar at 180°C
	PB500 red	25	25 bar - 10°C to 100°C	16.5 bar at 150°C
	PB500 yellow	25*	25 bar - 10°C to 100°C	16.5 bar at 150°C
	PB300 red/blue	16	16 bar - 10°C to 30°C	5 bar at 120°C
	PB300 yellow	16*	16 bar - 10°C to 30°C	5 bar at 120°C
	PB100	25	25 bar - 10°C to 100°C	4 bar at 120°C
gate valves	1065	17.5	17.5 bar - 0°C to 25°C	17.5 bar at 93°C
	1068	20	20 bar - 10°C to 100°C	9 bar at 180°C
	1072	32	32 bar - 10°C to 100°C	14 bar at 198°C
	1070/125	20	20 bar - 10°C to 100°C	9 bar at 180°C
	P81M	16	20 bar - 10°C to 100°C	9 bar at 180°C
	63	16	16 bar - 10°C to 30°C	5 bar at 120°C
globe valves	GM63	16	16 bar - 10°C to 30°C	5 bar at 120°C
	1029	32*	32 bar - 10°C to 100°C	14 bar at 198°C
	1031	32	32 bar - 10°C to 100°C	14 bar at 198°C
check valves	1039	32	32 bar - 10°C to 100°C	14 bar at 198°C
	1060A	25	25 bar - 10°C to 100°C	10.5 bar at 186°C
	1062	25	25 bar - 10°C to 100°C	10.5 bar at 186°C
	1063	8 - 12	0°C to 90°C	90°C
draincocks	1064	8 - 12	0°C to 90°C	90°C
	1832	10	10 bar - 0°C to 120°C	10 bar at 120°C
	833GM, GM LS	10	20 bar - 10°C to 100°C	13 bar at 120°C

\* 10 bar for Gas

## thread depths (mm)

Product	¼"	⅜"	½"	¾"	1"	1 ¼"	1 ½"	2"	2 ½"	3"	4"	
ball valves	PB700	S.E.P	S.E.P	S.E.P	S.E.P	S.E.P	Cat 1	Cat 1	Cat 1	Cat 1	Cat 1	Cat 1
	PB500 red	S.E.P	S.E.P	S.E.P	S.E.P	S.E.P	S.E.P	S.E.P	S.E.P	S.E.P	S.E.P	S.E.P
	PB500 yellow	S.E.P	S.E.P	S.E.P	S.E.P	S.E.P	Cat 1	Cat 1	Cat 1	Cat 1	Cat 1	Cat 1
	PB300 red/blue	-	-	S.E.P	S.E.P	S.E.P	S.E.P	S.E.P	S.E.P	-	-	-
	PB300 yellow	-	-	S.E.P	S.E.P	S.E.P	-	-	-	-	-	-
	PB100	-	-	S.E.P	S.E.P	S.E.P	S.E.P	S.E.P	S.E.P	-	-	-
gate valves	1065	-	-	S.E.P	S.E.P	S.E.P	S.E.P	S.E.P	S.E.P	-	-	-
	1068	-	-	S.E.P	S.E.P	S.E.P	S.E.P	S.E.P	S.E.P	S.E.P	S.E.P	S.E.P
	1072	-	-	S.E.P	S.E.P	S.E.P	S.E.P	S.E.P	S.E.P	-	-	-
	1070/125	S.E.P	S.E.P	S.E.P	S.E.P	S.E.P	S.E.P	S.E.P	S.E.P	S.E.P	S.E.P	S.E.P
	P81M	-	-	S.E.P	S.E.P	S.E.P	S.E.P	S.E.P	S.E.P	-	-	-
	63	-	-	S.E.P	S.E.P	S.E.P	S.E.P	-	-	-	-	-
globe valves	GM63	-	-	S.E.P	S.E.P	S.E.P	S.E.P	S.E.P	S.E.P	-	-	-
	1029	S.E.P	S.E.P	S.E.P	S.E.P	S.E.P	Cat 1	Cat 1	Cat 1	Cat 2	Cat 2	-
	1031	-	-	S.E.P	S.E.P	S.E.P	S.E.P	S.E.P	S.E.P	-	-	-
check valves	1039	-	-	S.E.P	S.E.P	S.E.P	S.E.P	S.E.P	S.E.P	-	-	-
	1060A	-	-	S.E.P	S.E.P	S.E.P	S.E.P	S.E.P	S.E.P	S.E.P	S.E.P	Cat 2
	1062	-	-	S.E.P	S.E.P	S.E.P	-	-	-	-	-	-
	1063	-	-	S.E.P	S.E.P	S.E.P	S.E.P	S.E.P	S.E.P	S.E.P	S.E.P	S.E.P
draincocks	1064	-	-	S.E.P	S.E.P	S.E.P	S.E.P	S.E.P	S.E.P	S.E.P	S.E.P	S.E.P
	1832	-	-	-	S.E.P	S.E.P	-	-	-	-	-	-
	833GM, GM LS	-	-	S.E.P	-	-	-	-	-	-	-	

Category 1 and Category 2 carry the CE mark

### further details

#### Pegler Yorkshire Group Limited

St. Catherine's avenue / Doncaster

South Yorkshire / DN4 8DF / England

tel: +44 (0) 800 1560 050

email: tech.help@pegleryorkshire.co.uk

[www.pegleryorkshire.co.uk](http://www.pegleryorkshire.co.uk)

# connection instructions

## threaded connections

Ensure that threads are prepared correctly to provide a good and long lasting service.

Thread compound should be applied to male ends only and not directly into the valve.

Valves should not be over tightened with a wrench.

Ensure the male thread is the correct type and length. If the thread is too short a leak may occur. If the thread is too long then damage may be made to the valve.

Ensure that good quality tools are used to provide an accurate joint and therefore avoiding the risk of leaking.

Thread tape may be used and applied to the external of the male thread after the threads have been cleaned.

### **Joining the valve and pipe**

Fix the threaded pipe into a vice and then turn the valve on to the pipe.

A close fitting spanner should be applied to the valve hexagon/octagon flats being fixed. By tightening the valve onto the pipe in this way, the valve avoids being distorted with the consequential damage to internal parts.

## further details

---

### **Pegler Yorkshire Group Limited**

St. Catherine's avenue / Doncaster

South Yorkshire / DN4 8DF / England

**tel:** +44 (0) 800 1560 050

**email:** [tech.help@pegleryorkshire.co.uk](mailto:tech.help@pegleryorkshire.co.uk)

[www.pegleryorkshire.co.uk](http://www.pegleryorkshire.co.uk)